

Type D3 PROTECTOSPRAY Directional Spray Nozzles, Open, TFP802 Appendix Material

IMPORTANT

Refer to Technical Data Sheet TFP2300 for warnings pertaining to regulatory and health information. Always refer to Technical Data Sheet TFP700 for the "INSTALLER WARNING" that provides cautions with respect to handling and installation of sprinkler systems and components. Improper handling and installation can permanently damage a sprinkler system or its components and cause the sprinkler to fail to operate in a fire situation or cause it to operate prematurely.

Scan the QR code or enter the URL in a web browser to access the most up-to-date electronic version of this document. Data rates may apply.



docs.jci.com/tycofire/TFP802A

General Description

TYCO Type D3 PROTECTOSPRAY Nozzles are open (non-automatic) directional spray nozzles and they are designed for use in water spray fixed systems for fire protection applications. The Type D3 Nozzles are external deflector-type nozzles that discharge a uniformly filled cone of medium velocity water droplets.

They are especially effective in covering exposed vertical, horizontal, curved, and irregular shaped surfaces in a cooling spray to prevent excessive absorption of heat from an external fire and possible structural damage or spread of fire to the protected equipment. In some applications, depending on water design density requirements, they may also be used for fire control and extinguishment.

The Type D3 Nozzles are available in a wide variety of orifice sizes and spray profile angles (included angles of discharge), as described in Technical Data Sheet TFP802, to provide versatility in system design.

NOTICE

The Type D3 PROTECTOSPRAY Nozzles described herein must be installed and maintained in compliance with Technical Data Sheet TFP802, as well as with the applicable standards of the NATIONAL FIRE PROTECTION ASSOCIATION (NFPA), in addition to the standards of any other authorities having jurisdiction. Failure to do so may impair the performance of these devices.

The owner is responsible for maintaining their fire protection system and devices in proper operating condition. Contact the installing contractor or product manufacturer with any questions.



Appendix Material

As fixed directional spray nozzles, TYCO Type D3 PROTECTOSPRAY Nozzles can be installed at any fixed angle of 0 degrees (pointed straight down) to 180 degrees (pointed straight up). As a function of the fixed angle, i.e., installed position, the maximum axial distance between the nozzle tip and the plane-of-protection at which the spray profile remains concentric with the centerline of the nozzle varies due to the combination of the water spray exit velocity and affect of gravity. The axial distance, therefore, becomes shorter as the fixed angle is changed from 0 degrees to 180 degrees.

Technical Data Sheet TFP802 provides the maximum axial distance for exposure protection over the fixed angle range of 0 to 180 degrees. Figures 1 through 7 in this technical data sheet have been prepared as reference to illustrate the fixed angles of 0 degrees and 90 degrees. These illustrations have been based on the information provided in Technical Data Sheet TFP802.

Limited Warranty

For warranty terms and conditions, visit www.tyco-fire.com.

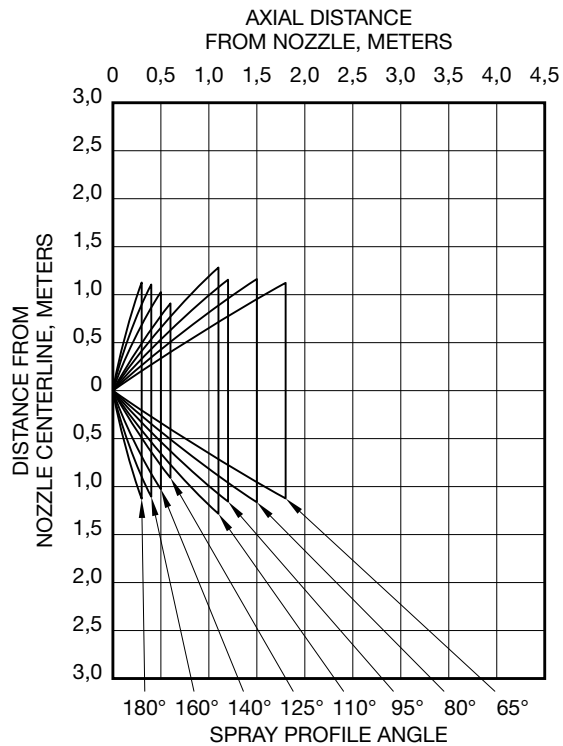
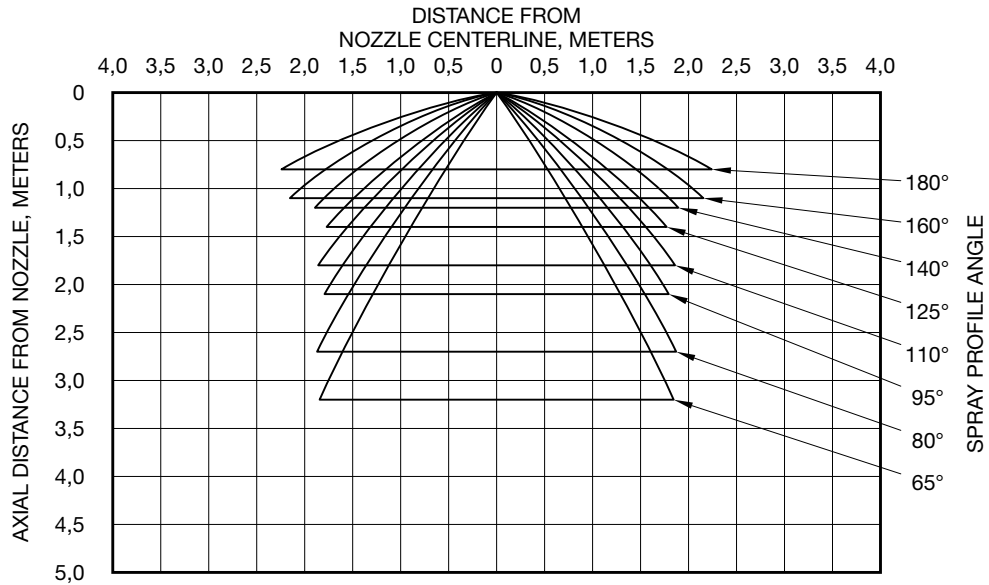

FIGURE 1
NO. 16 ORIFICE – SPRAY PROFILES
AT 0 DEGREES (DOWN) AND 90 DEGREES (HORIZONTAL) FIXED ANGLE OF ORIENTATION

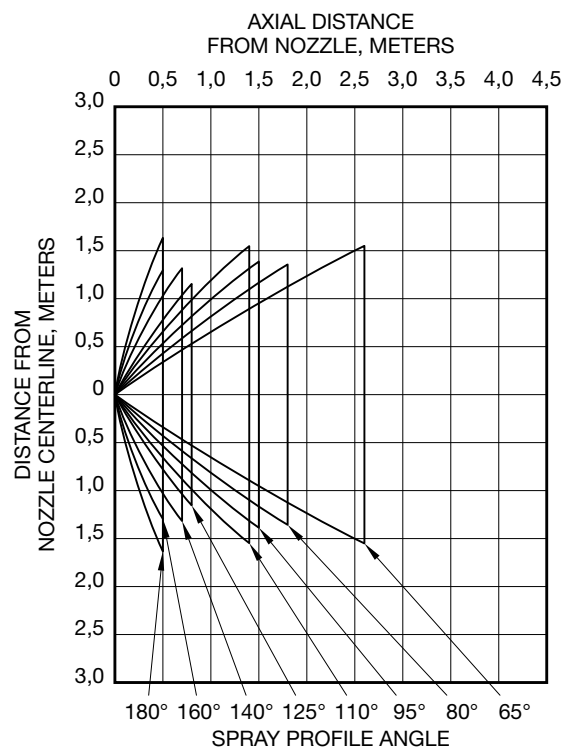
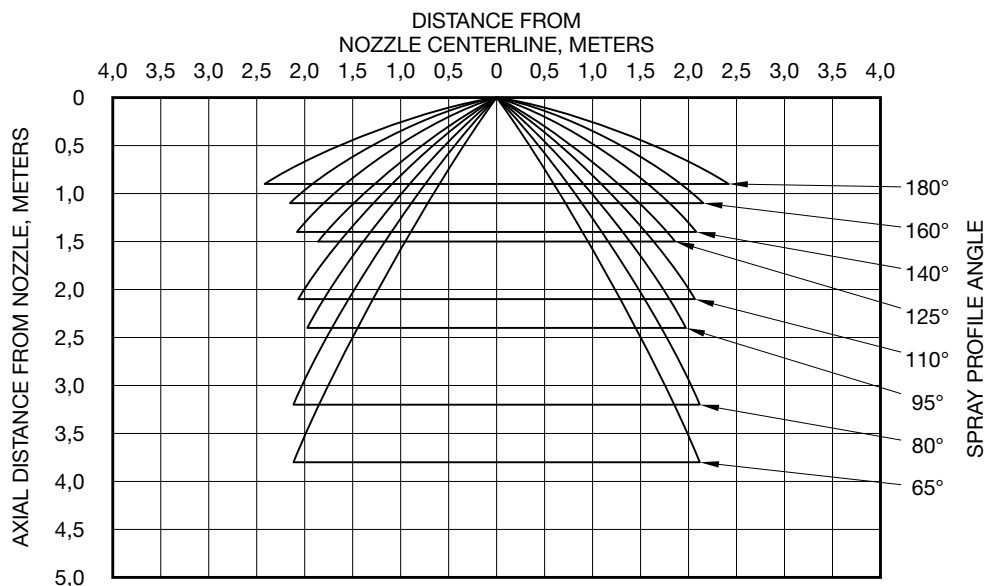

FIGURE 2
NO. 18 ORIFICE – SPRAY PROFILES
AT 0 DEGREES (DOWN) AND 90 DEGREES (HORIZONTAL) FIXED ANGLE OF ORIENTATION

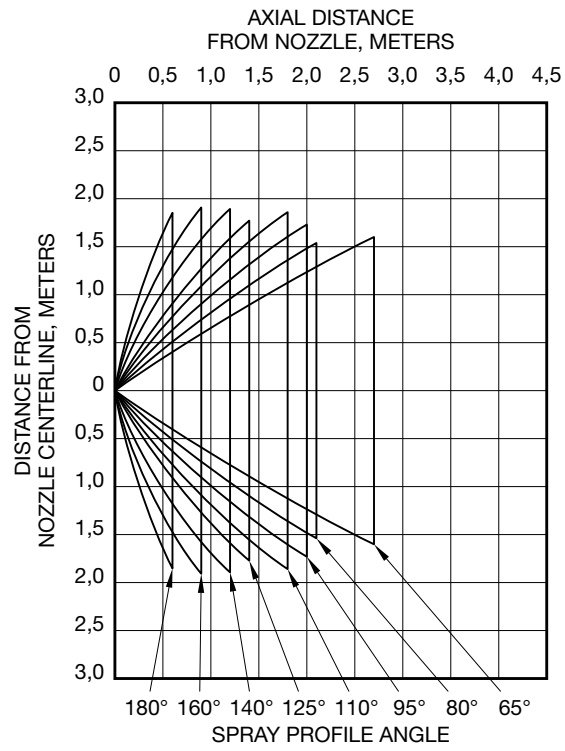
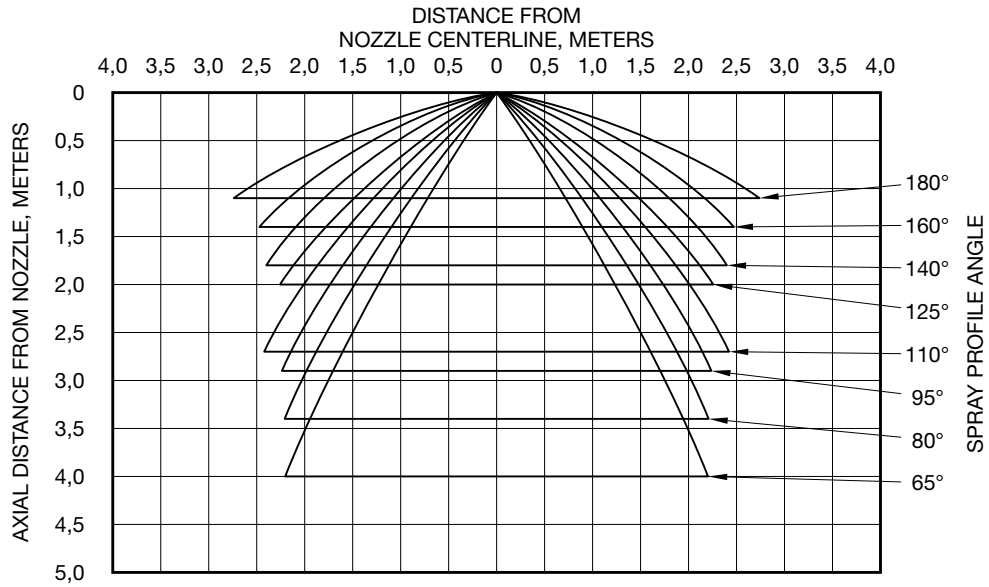

FIGURE 3
NO. 21 ORIFICE – SPRAY PROFILES
AT 0 DEGREES (DOWN) AND 90 DEGREES (HORIZONTAL) FIXED ANGLE OF ORIENTATION

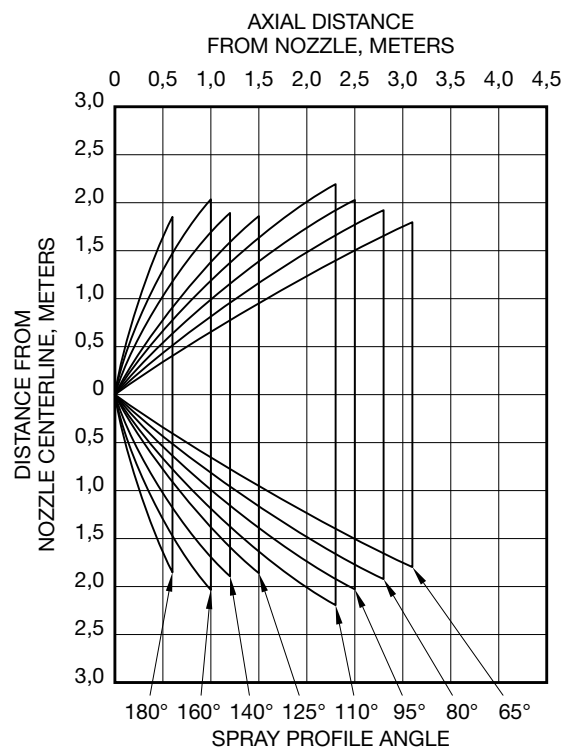
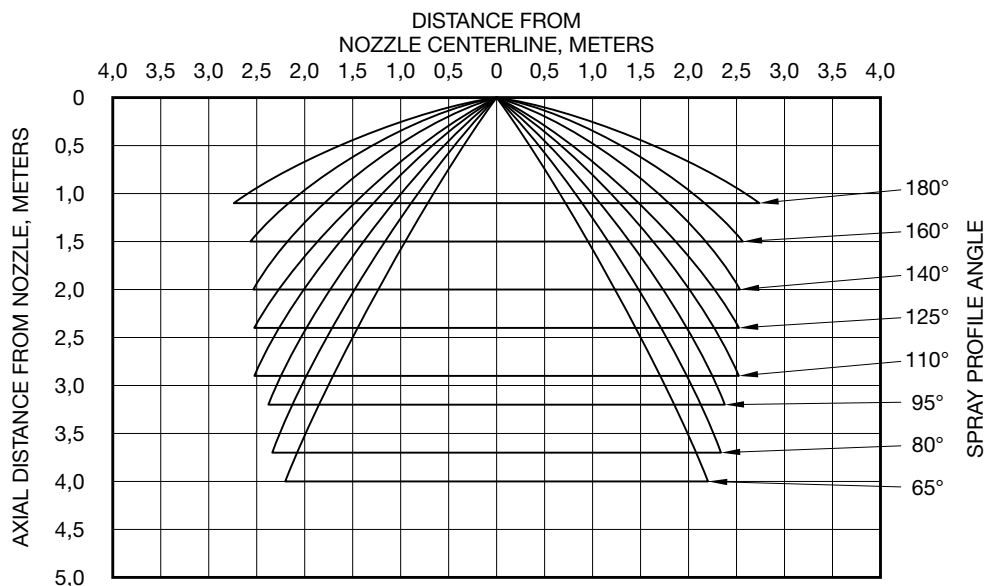

FIGURE 4
NO. 24 ORIFICE – SPRAY PROFILES
AT 0 DEGREES (DOWN) AND 90 DEGREES (HORIZONTAL) FIXED ANGLE OF ORIENTATION

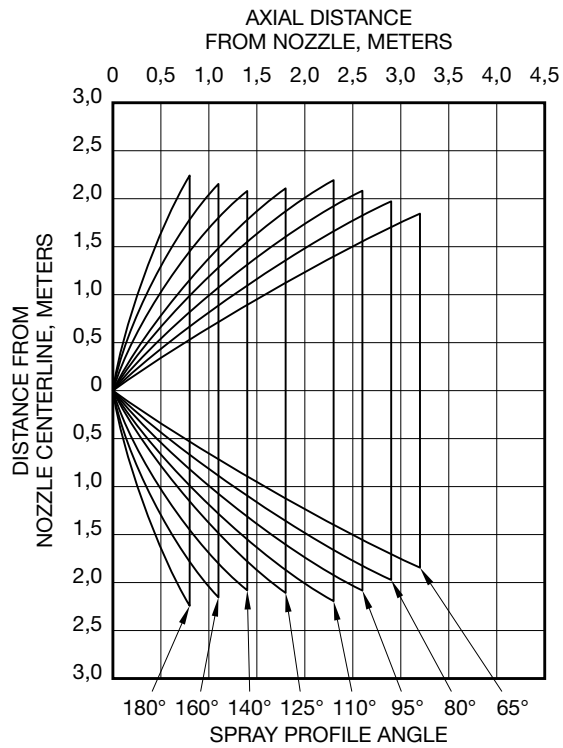
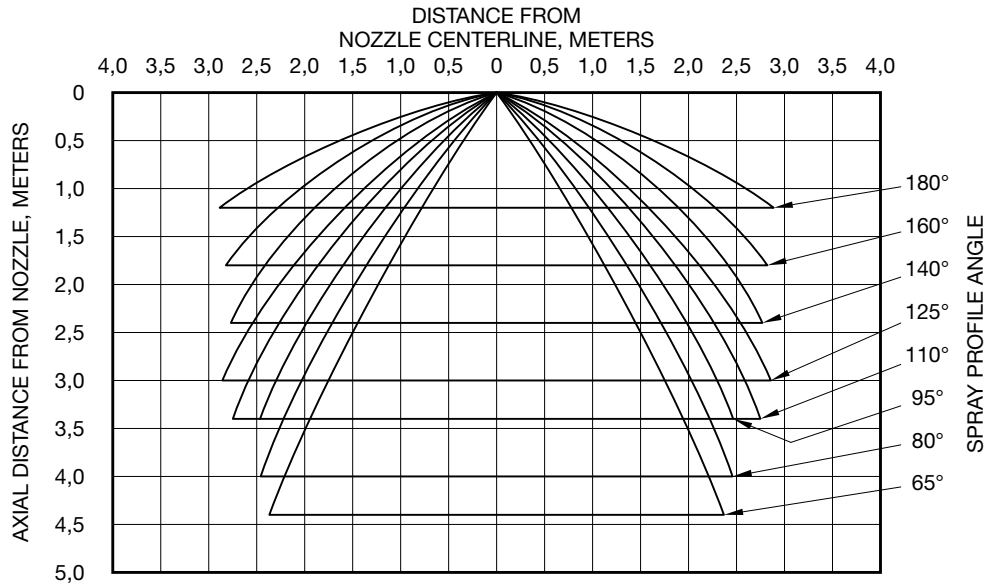

FIGURE 5
NO. 28 ORIFICE – SPRAY PROFILES
AT 0 DEGREES (DOWN) AND 90 DEGREES (HORIZONTAL) FIXED ANGLE OF ORIENTATION

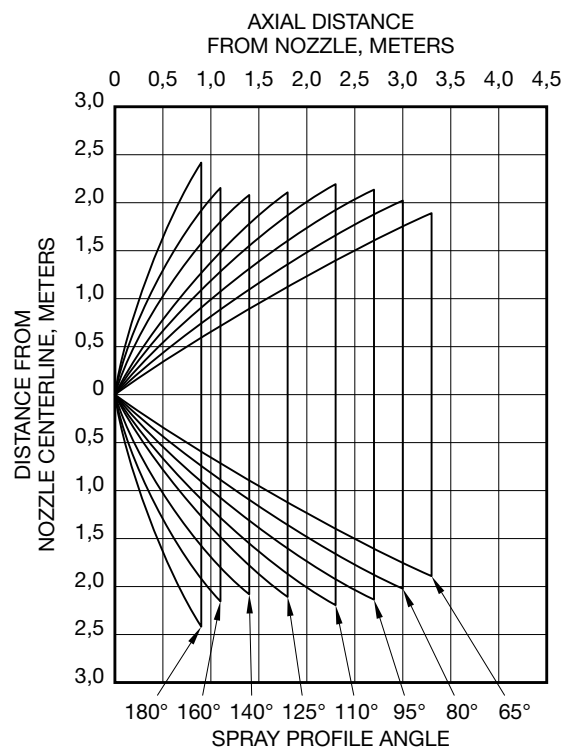
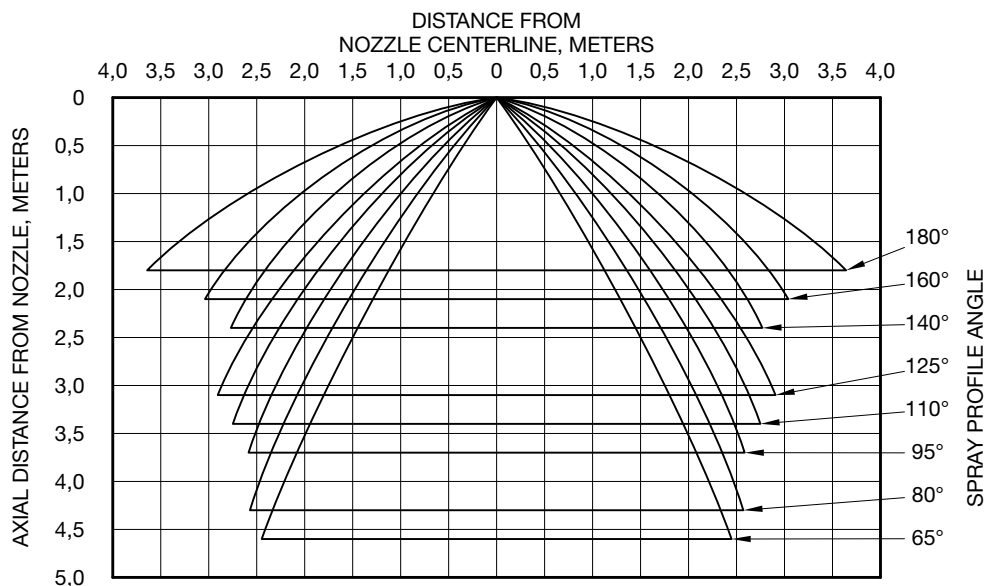

FIGURE 6
NO. 32 ORIFICE – SPRAY PROFILES
AT 0 DEGREES (DOWN) AND 90 DEGREES (HORIZONTAL) FIXED ANGLE OF ORIENTATION

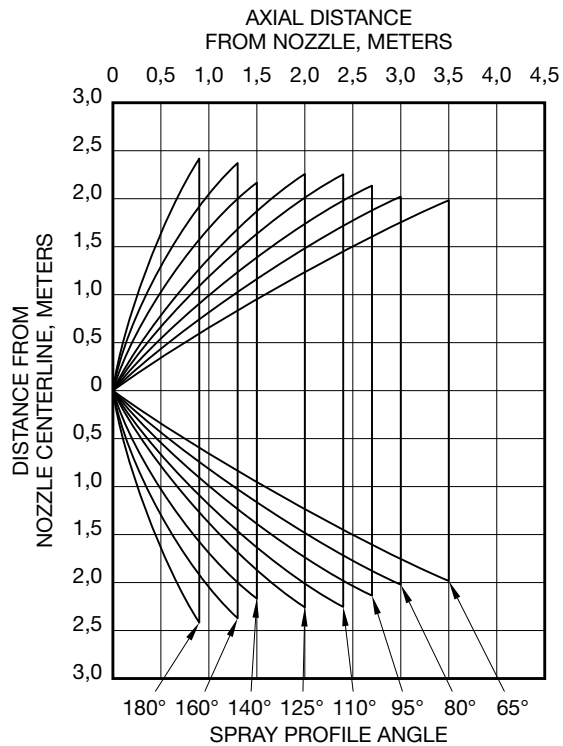
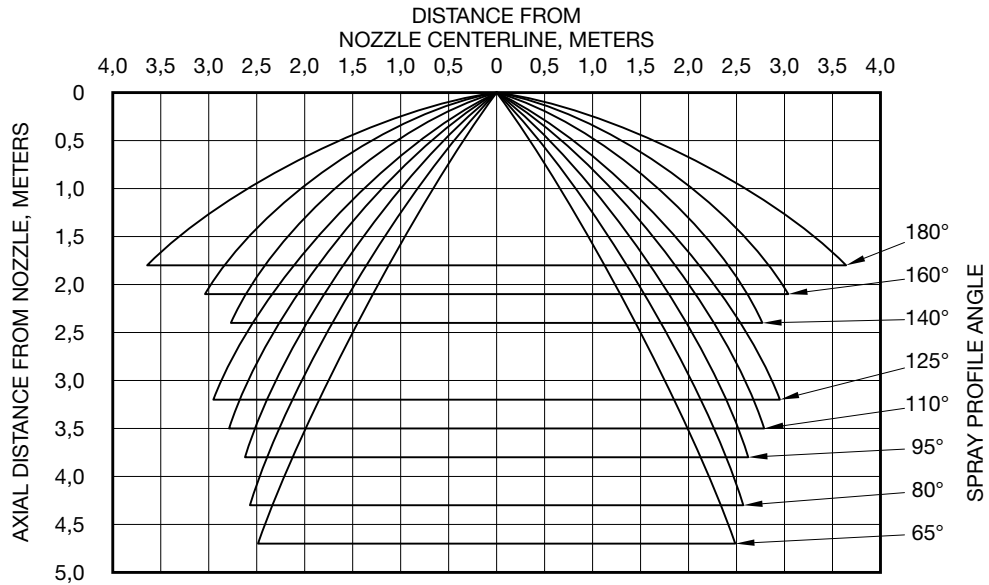

FIGURE 7
NO. 34 ORIFICE – SPRAY PROFILES
AT 0 DEGREES (DOWN) AND 90 DEGREES (HORIZONTAL) FIXED ANGLE OF ORIENTATION